

# LCD03 - I2C/Serial LCD

## Technical Documentation



### Overview

The I2C and serial display driver provides easy operation of a standard 20\*4 LCD Text display. It requires only a 5v power supply and the two data connections for either mode, freeing up pins on your processor. Many useful text formatting functions are provided (described below) and also the ability to put together custom characters into memory which can be called off as required. There is a 64 byte FIFO buffer to ensure a minimum of delay in writing to the display.

The LCD03 is the same as the LCD02 apart from the added ability to control the backlight in software. It is now easily possible to turn the backlight on and off by sending commands via the I2C / Serial link.

### Connections

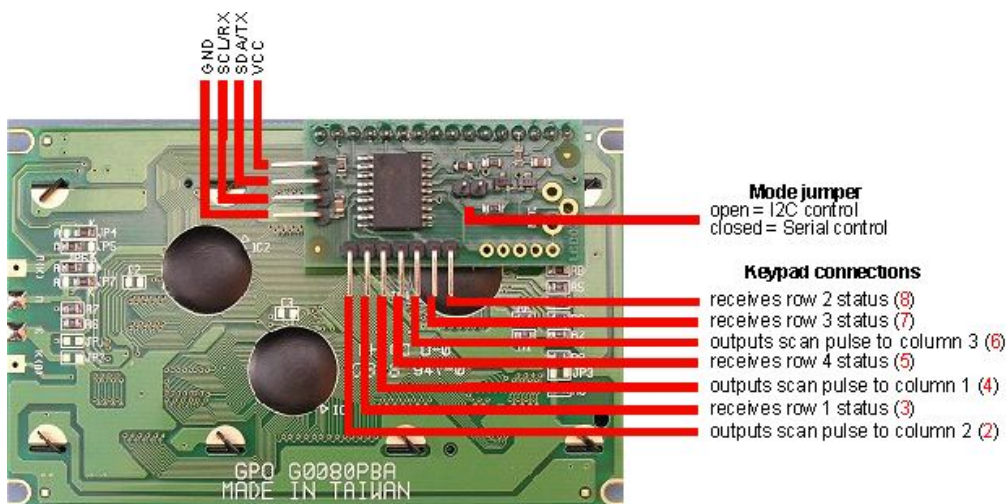

Easy connections  
for 3\*4  
keypad, just wire  
pins 2-8  
to corresponding  
red  
numbers

Pins 1 and 9 are unconnected - only pins 2 - 8 are used.

### Serial/I2C Mode selection

A single jumper link is used to select Serial or I2C mode. When the jumper is present (factory default) the module is in serial mode. When the jumper is removed the module is in I2C mode. The mode jumper is only checked as part of the power-up sequence, so make sure the display is off before changing modes. If you change the link position while the module is powered, nothing will change until next time you switch on.

## FIFO

Because the I2C communications operate faster than the display can accept data, all commands and text you send to the display are placed in the FIFO (First In, First Out) buffer. This data is sent to the display as fast as it will accept it. The FIFO is 64 bytes in length and the number of free bytes can be returned in either mode. When sending lots of text to the display, you should check the number of free bytes so you don't overflow the buffer. If the buffer does overflow, the excess bytes are ignored. The FIFO buffer exists in Serial mode too, but at 9600 the display is fast enough and you are unlikely to need to check it.

## I2C Operation

### I2C Bus

The I2C display is located on the I2C bus at an address of 0XC6. The SCL and SDA lines should have pull-up resistors on them somewhere on the bus. You only require 1 pair of resistors for the whole I2C bus, not specifically for the LCD03. They are normally on the master controller and you may already have them. If not, anything between 1k8 and 10k should work. I recommend 1k8 for best noise immunity. We have some example code for the PIC16F877 using the Hitech C compiler [here](#), and the compiled hex [here](#).

### Display control commands

The LCD03 has four registers, three of which are read only information registers. Register 0 is a dual purpose register, when written, it is the command register where all of the instructions from the commands section should be sent. When read it returns the number of free bytes in the FIFO buffer.

register	Read	Write
0	Number of free bytes in FIFO buffer	Command register
1	Keypad state Low byte	x
2	Keypad state High byte	x
3	Version	x

## Serial operation

The Serial mode operates over a link with a baud rate of 9600 bps (no parity, 2 stop bits) and 5v signals, Do NOT connect RS232 directly to the module - you will destroy it. Use a MAX232 or equivalent to convert the RS232 levels to 5v. Operation is with the same command set as the I2C mode with an additional set of commands to request data to be sent i.e. the software version.

### Commands (for both I2C and Serial)

decimal	command	description
0	null (ignored)	Ignored as a no operation
1	Cursor Home	Sets the cursor to the home position (top left)
2	Set cursor (1-80)	Cursor to a position specified by the next byte, where 1 is the top left and 80 is the bottom right
3	set cursor (line, column)	Sets cursor using two bytes, where first byte is the line and the second byte is the column
4	Hide cursor	stops the position cursor from appearing on the display
5	Show underline cursor	Changes the cursor to the underline type
6	Show blinking cursor	Changes the cursor to the blinking type
8	Backspace	deletes the preceding character from the current position on the display
9	Horizontal tab (by tab set)	Moves the current position across by the tab space set by command 18 (default tab space 4)
10	Smart line feed	Moves the cursor down one line to the position beneath in the same column
11	Vertical tab	Moves the cursor up one line to the position above in the same column
12	Clear screen	Clears the screen and sets cursor to the home position
13	Carriage Return	Moves the cursor to the start of the next line
17	Clear Column	Clears the contents of the current column and moves cursor right by one column
18	Tab set	Sets the required tab size, the following byte can be a size of between 1 and 10
19	Backlight on	Turns the backlight of the LCD03 on
20	Backlight off (default)	Turns the backlight of the LCD03 off
27	Custom char generator	allows 8 custom chars to be built. See custom char generator below
32-255	ASCII chars	Writes ASCII chars straight to the display

## Additional commands (Serial only)

decimal	command	description
14	FIFO status	Results in the module returning its FIFO status, the number of free bytes from 0 to 64
15	Software version	Results in the module returning its single byte software version
16	Keypad status	Returns keypad input status, two bytes returned with the low byte first (see keypad section)

### Custom char generator

Custom characters can be generated by sending an 8 byte map. The first thing that must be done is to send a command of 27 to indicate that you intend to make a custom char. Next you have to specify the position in ram of one of the 8 available chars you intend to build, the 8 chars are mapped at positions 128-135. Then the pattern should be sent as below.

How to calculate an 8 byte character pattern:

Eight bytes are sent with the highest bit masked on, the next two bits are ignored (x) and the final 5 bits show the line pattern.

	Bit	Bit	Bit	Bit	Bit	
	4	3	2	1	0	sent byte
<b>Byte 0</b>						1xx00000 (128)
<b>Byte 1</b>						1xx00100 (132)
<b>Byte 2</b>						1xx01110 (142)
<b>Byte 3</b>						1xx10101 (149)
<b>Byte 4</b>						1xx00100 (132)
<b>Byte 5</b>						1xx00100 (132)
<b>Byte 6</b>						1xx00100 (132)
<b>Byte 7</b>						1xx00000 (128)

So to build the above arrow into location 128 you would send this sequence to the command register:

- 27 (char generate command)
- 128 (location to be filled)
- 128 (byte 0)
- 132 (byte1)
- 142 (byte2)
- 149 (byte3)
- 132 (byte 4)
- 132 (byte 5)
- 132 (byte 6)
- 128 (byte 7)

Now the char is built into a memory location it can be called at any time as long as the module remains powered by simply sending the address between 128 and 135.

### Keypad input

An added feature of the module is the ability to connect a 3\*4 Keypad, the module will automatically scan the status of the keys at regular intervals. The result is then provided in two bytes for easy use, shown by the diagram below. Each bit represents the row and column of each button on the keypad. The second row is the keypad characters when using our keypad.

High byte								Low byte							
0	0	0	0	4/3	4/2	4/1	3/3	3/2	3/1	2/3	2/2	2/1	1/3	1/2	1/1
0	0	0	0	#	0	*	9	8	7	6	5	4	3	2	1

Any key press will result in the corresponding bit in the byte being driven high. In I2C mode these bytes are available for reading from registers one and two.

In serial mode, just send 16 to the LCD03 and it will reply with the two bytes as above with the low byte first.

### LCD Module Dimensions

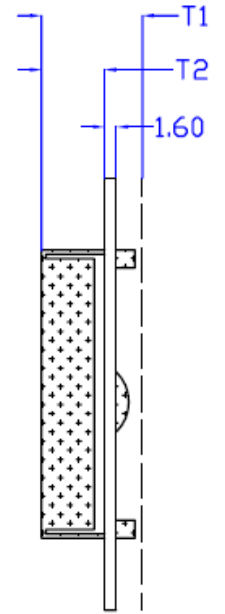
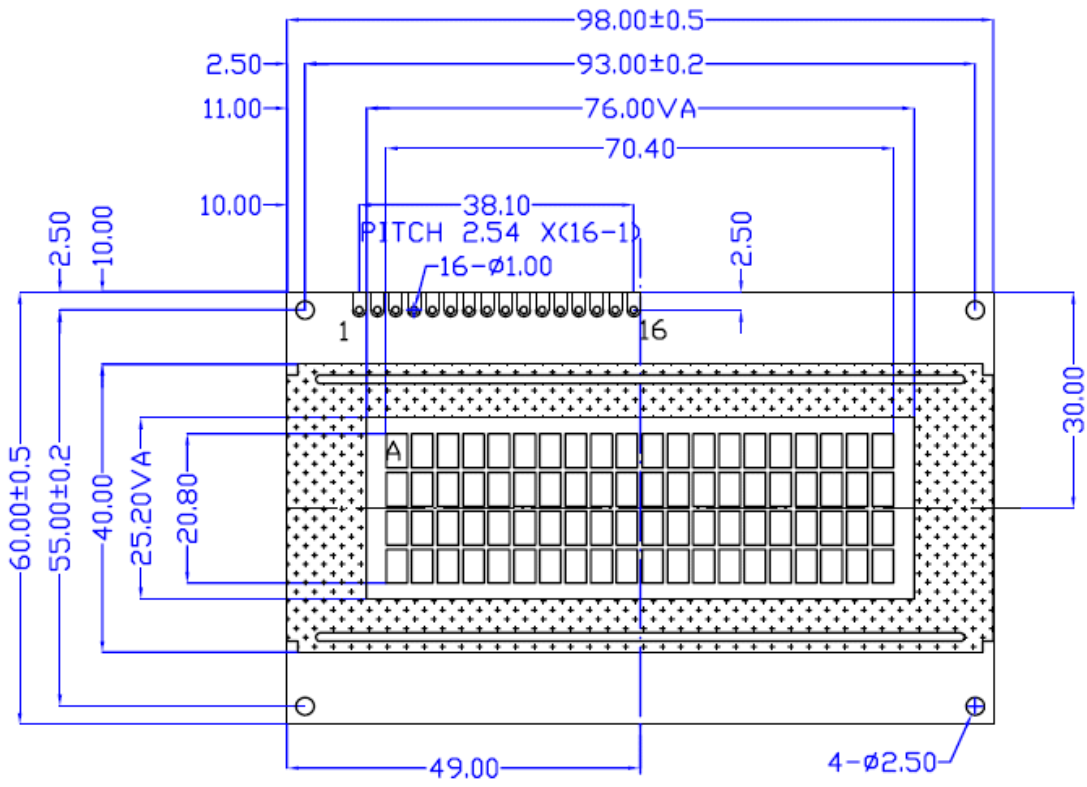

\* FOR LED BACKLIGHT  
 T1=14.0MAX T2=9.0±0.3