



Feature

- ON/OFF delay
- Minimum detectable distance configuration
- Minimum detectable width configuration
- Possible to register 16 areas by digital inputs
- Malfunction output and 3 detecting output are provided

Specifications

Model No.	UXM-30LN-PW
Power source	10 to 30VDC
Light source	Semiconductor laser ($\lambda = 905\text{nm}$), Laser safety class 1 (FDA)
Supply current	Regular current: 600mA or less (at 10VDC and 12VDC) 250mA or less (at 24VDC) Start-up current: 2A or less (at 10VDC), 1.5A or less (at 12VDC), 0.75A or less (at 24VDC)
Power consumption	6W or less (at Regular)
Detection range and object	Guaranteed range : 0.1 to 30m ² (500mm × 500mm of Black objects with 10% reflectance) Max. detection range : 100m (limit value) Min. objects : 65mm (at 5m), 130mm (at 10m), 400mm (at 30m)
Distance accuracy	3,000lx or less : $\pm 50\text{mm}^{*1}$: (black objects with 10% reflectance up to 10m and white paper up to 30m) 100,000lx or less ^{*2} : $\pm 100\text{mm}^{*1}$: (black objects with 10% reflectance up to 10m and white paper up to 30m)
Measuring resolution/repeatability	1mm 3,000lx or less : $\sigma < 50\text{mm}$ (black objects with 10% reflectance up to 10m and white paper up to 30m) 100,000lx or less : $\sigma < 100\text{mm}$ (black objects with 10% reflectance up to 10m and white paper up to 30m)
Scanning angle	190°

Angular resolution	Approx.0.25° (360° / 1,440 steps)
Detection area setting	It is available settings in 0.1 to 30m range by points or input the coordinate value
Scanning speed	50msec (Motor rotating number 1200rpm)
Interface	USB Ver. 2.0 FS <full speed> mode (12Mbps) for Area setting
Output	4 output signal : Error output, Output 1, 2 and 3
Input	4 input signal : Area changeover input 1, 2, 3 and 4 (Max. 16 patterns)
Response time	100ms or less (However it varies depending on the setting condition)
Start up time	in 30 seconds from power on (However it might beyond 30 seconds depending on the condition)
Indication lamp	Power (Green), Operation/Error (Orange) : Operating (ON), Error (blink)
Connection	Power and input/output : wire cable USB: connector (Binder brand : model number 09-0431-87-04)
Ambient temperature/ humidity	-10 to +50 degrees C, 85%RH or less (Not condensing and icing)
Environmental effect	Measured distance will be shorter than the actual distance under rain, snow and sunlight*2.
Vibration resistance	10 to 55Hz, double amplitude 1.5mm Each 2 hour in X, Y and Z directions 55 to 200Hz, 19.6 m/s ² sweep of 2min Each 1 hour in X, Y and Z directions
Impact resistance	196m/s ² Each 10 time in X, Y and Z directions
Protective structure	IP67
Insulation resistance	10MΩ
Weight	800g
Material	Front case : Polycarbonate, rear case : Aluminum
Dimensions(W×D×H)	124mm×126mm×150mm (excluding connector)

*1 Accuracy can not be guaranteed under direct sunlight.

*2 Make sure of the sensor functions under operating environment.

External dimension

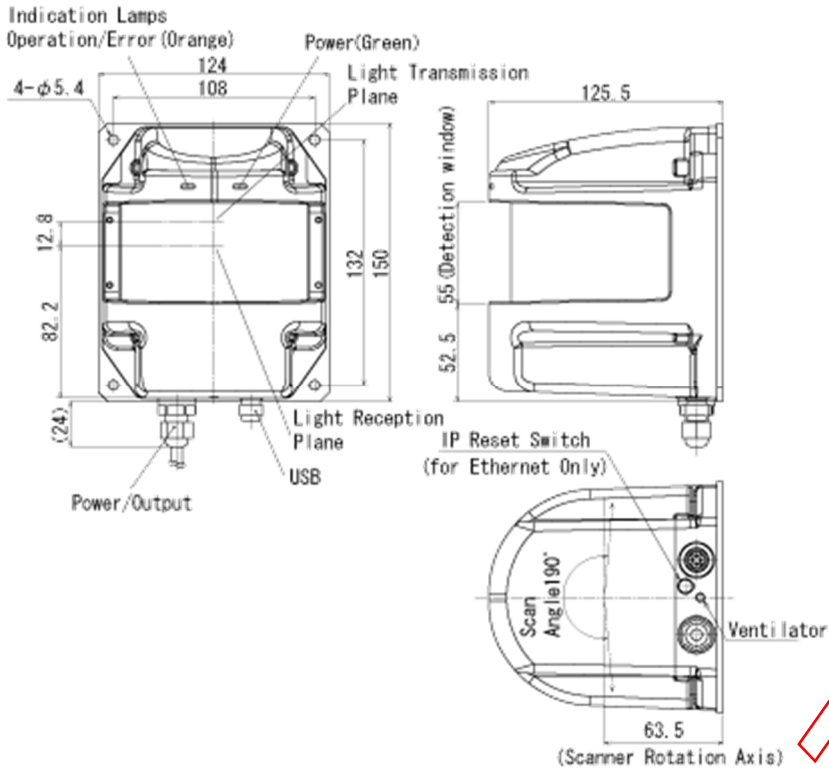

USB cable for UXM series

