

MX-64T / MX-64R

Parts Photo



※ Control Table's Compliance replaced by PID.

※ The control table's order for PID has changed to DIP from this version onwards. Please make reference of this change.

※ Although the MX-64T (TTL) and MX-64R (RS-485) differ in communications protocols both have the same features and perform equally. (TTL uses 3-pin connectors while RS-485 uses 4)

H/W Specification

- MCU : ST CORTEX-M3 (STM32F103C8 @ 72MHZ,32BIT)
- POSITION SENSOR : Contactless absolute encoder (12BIT,360 DEGREE)
- MOTOR : Maxon
- BAUD RATE : 8000 bps ~ 4.5 Mbps
- CONTROL ALGORITHM : PID CONTROL
- Resolution : 0.088°
- Running Degree
 - 0° ~ 360°
 - Endless Turn
- Weight : 126g
- Dimension : 40.2mm x 61.1mm x 41mm
- Gear Reduction Ratio : 200 : 1
- Stall Torque
 - 5.5N.m (at 11.1V, 3.9A),
 - 6.0N.m (at 12V, 4.1A)
 - 7.3N.m (at 14.8V, 5.2A)
- No load speed
 - 58rpm (at 11.1V)
 - 63rpm (at 12V)
 - 78rpm (at 14.8V)
- Running Temperature : -5°C ~ +80°C

- **Voltage : 10 ~ 14.8V (Recommended Voltage 12V)**
- Command Signal : Digital Packet
- Protocol Type
 - MX-64T (Half duplex Asynchronous Serial Communication (8bit,1stop, No Parity))
 - MX-64R (RS485 Asynchronous Serial Communication (8bit,1stop, No Parity))
- Link (Physical)
 - MX-64T (TTL Level Multi Drop Bus)
 - MX-64R (RS485 Multi Drop Bus)
- ID : 254 ID (0~253)
- Feedback : Position, Temperature, Load, Input Voltage, etc.
- Material : Full Metal Gear, Engineering Plastic Body
- Standby current : 100 mA

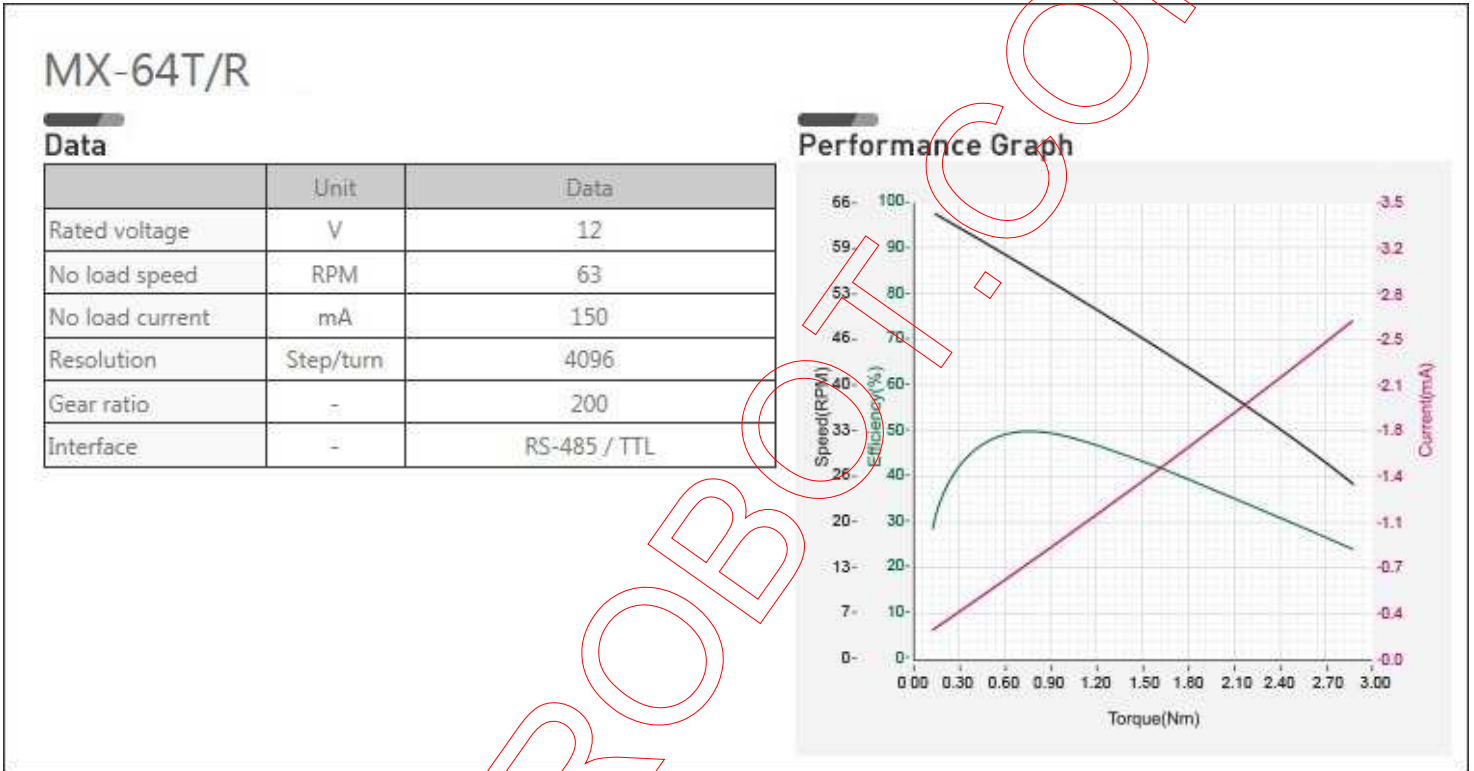

Precautions when connecting to power supply!

- For the stable power supply, we recommend using ROBOTIS controller or SMPS2Dynamixel.
- Connect your DYNAMIXEL to power supply while it's off and turn on/off with the power switch.

Control Table

Control Table consists of data regarding the current status and operation, which exists inside of Dynamixel. The user can control Dynamixel by changing data of Control Table via Instruction Packet.

EEPROM and RAM

Data in RAM area is reset to the initial value whenever the power is turned on while data in EEPROM area is kept once the value is set even if the power is turned off.

Address

It represents the location of data. To read from or write data to Control Table, the user should assign the correct address in the Instruction Packet.

Access

Dynamixel has two kinds of data: Read-only data, which is mainly used for sensing, and Read-and-Write data, which is used for driving.

Initial Value

In case of data in the EEPROM Area, the initial values on the right side of the below Control Table are the factory default settings. In case of data in the RAM Area, the initial values on the right side of the above Control Tables are the ones when the power is turned on.

Highest/Lowest Byte

In the Control table, some data share the same name, but they are attached with (L) or (H) at the end of each name to distinguish the address. This data requires 16bit, but it is divided into 8bit each for the addresses (low) and (high). These two addresses should be written with one Instruction Packet at the same time.

Area	Address (Hexadecimal)	Name	Description	Access	Initial Value (Hexadecimal)
EEPROM	0 (0X00)	Model Number(L)	Lowest byte of model number	R	54 (0X36)
	1 (0X01)	Model Number(H)	Highest byte of model number	R	1 (0X01)
	2 (0X02)	Version of Firmware	Information on the version of firmware	R	-
	3 (0X03)	ID	ID of Dynamixel	RW	1 (0X01)
	4 (0X04)	Baud Rate	Baud Rate of Dynamixel	RW	34 (0X22)
	5 (0X05)	Return Delay Time	Return Delay Time	RW	250 (0XFA)
	6 (0X06)	CW Angle Limit(L)	Lowest byte of clockwise Angle Limit	RW	0 (0X00)
	7 (0X07)	CW Angle Limit(H)	Highest byte of clockwise Angle Limit	RW	0 (0X00)
	8 (0X08)	CCW Angle Limit(L)	Lowest byte of counterclockwise Angle Limit	RW	255 (0XFF)
	9 (0X09)	CCW Angle Limit(H)	Highest byte of counterclockwise Angle Limit	RW	15 (0X0F)
	11 (0X0B)	the Highest Limit Temperature	Internal Limit Temperature	RW	80 (0X50)
	12 (0X0C)	the Lowest Limit Voltage	Lowest Limit Voltage	RW	60 (0X3C)
	13 (0X0D)	the Highest Limit Voltage	Highest Limit Voltage	RW	160 (0XA0)
	14 (0X0E)	Max Torque(L)	Lowest byte of Max. Torque	RW	255 (0XFF)
	15 (0X0F)	Max Torque(H)	Highest byte of Max. Torque	RW	3 (0X03)
	16 (0X10)	Status Return Level	Status Return Level	RW	2 (0X02)
	17 (0X11)	Alarm LED	LED for Alarm	RW	36 (0X24)
	18 (0X12)	Alarm Shutdown	Shutdown for Alarm	RW	36 (0X24)
	20 (0X14)	Multi Turn Offset(L)	multi-turn offset least significant byte (LSB)	RW	0 (0X00)
	21 (0X12)	Multi Turn Offset(H)	multi-turn offset most significant byte (MSB)	RW	0 (0X00)
	22 (0X12)	Resolution Divider	Resolution divider	RW	1 (0X01)
	RAM	24 (0X18)	Torque Enable	Torque On/Off	RW
25 (0X19)		LED	LED On/Off	RW	0 (0X00)
26 (0X1A)		D Gain	Derivative Gain	RW	0 (0X00)
27 (0X1B)		I Gain	Integral Gain	RW	0 (0X00)
28 (0X1C)		P Gain	Proportional Gain	RW	32 (0X20)
30 (0X1E)		Goal Position(L)	Lowest byte of Goal Position	RW	-
31 (0X1F)		Goal Position(H)	Highest byte of Goal Position	RW	-
32 (0X20)		Moving Speed(L)	Lowest byte of Moving Speed	RW	-
33 (0X21)		Moving Speed(H)	Highest byte of Moving Speed	RW	-
34 (0X22)		Torque Limit(L)	Lowest byte of Torque Limit	RW	ADD14
35 (0X23)		Torque Limit(H)	Highest byte of Torque Limit	RW	ADD15
36 (0X24)		Present Position(L)	Lowest byte of Current Position	R	-

37 (0X25)	Present Position(H)	Highest byte of Current Position	R	-
38 (0X26)	Present Speed(L)	Lowest byte of Current Speed	R	-
39 (0X27)	Present Speed(H)	Highest byte of Current Speed	R	-
40 (0X28)	Present Load(L)	Lowest byte of Current Load	R	-
41 (0X29)	Present Load(H)	Highest byte of Current Load	R	-
42 (0X2A)	Present Voltage	Current Voltage	R	-
43 (0X2B)	Present Temperature	Current Temperature	R	-
44 (0X2C)	Registered	Means if instruction is registered	R	0 (0X00)
46 (0X2E)	Moving	Means if there is any movement	R	0 (0X00)
47 (0X2F)	Lock	Locking EEPROM	RW	0 (0X00)
48 (0X30)	Punch(L)	Lowest byte of Punch	RW	0 (0X00)
49 (0X31)	Punch(H)	Highest byte of Punch	RW	0 (0X00)
68 (0X44)	Current(L)	Lowest byte of Consuming Current	RW	0 (0X00)
69 (0X45)	Current(H)	Highest byte of Consuming Current	RW	0 (0X00)
70 (0X46)	Torque Control Mode Enable	Torque control mode on/off	RW	0 (0X00)
71 (0X47)	Goal Torque(L)	Lowest byte of goal torque value	RW	0 (0X00)
72 (0X48)	Goal Torque(H)	Highest byte of goal torque value	RW	0 (0X00)
73 (0X49)	Goal Acceleration	Goal Acceleration	RW	0 (0X00)

Address Function Help

EEPROM Area

Model Number

It represents the Model Number.

Firmware Version

It represents the firmware version.

ID

It is a unique number to identify Dynamixel.

The range from 0 to 252 (0xFC) can be used, and, especially, 254(0xFE) is used as the Broadcast ID.

If the Broadcast ID is used to transmit Instruction Packet, we can command to all Dynamixels.

Please be careful not to duplicate the ID of connected Dynamixel.

Baud Rate

It is the baud rate to communicate with controller. It is available in between 0~254(0xFE).

If the data value is in between 0~249 :

$$\text{Baudrate(BPS)} = 2000000 / (\text{Data} + 1)$$

Data	Set BPS	Target BPS	Tolerance
1	1000000.0	1000000.0	0.000 %
3	500000.0	500000.0	0.000 %
4	400000.0	400000.0	0.000 %
7	250000.0	250000.0	0.000 %

9	200000.0	200000.0	0.000 %
16	117647.1	115200.0	-2.124 %
34	57142.9	57600.0	0.794 %
103	19230.8	19200.0	-0.160 %
207	9615.4	9600.0	-0.160 %

If the data value is over the 250 :

Data	Set BPS	Target BPS	Tolerance
250	2250000.0	2250000.0	0.000 %
251	2500000.0	2500000.0	0.000 %
252	3000000.0	3000000.0	0.000 %

Note : Maximum Baud Rate error of 3% is within the tolerance of UART communication.

Return Delay Time

It is the delay time per data value that takes from the transmission of Instruction Packet until the return of Status Packet. 0 to 254 (0xFE) can be used, and the delay time per data value is 2 usec.

That is to say, if the data value is 10, 20 usec is delayed. The initial value is 250 (0xFA) (i.e., 0.5 msec).

CW/CCW Angle Limit

The angle limit allows the motion to be restrained.

The range and the unit of the value is the same as Goal Position(Address 30, 31).

- CW Angle Limit: the minimum value of Goal Position(Address 30, 31)
- CCW Angle Limit: the maximum value of Goal Position(Address 30, 31)

The following two modes can be set pursuant to the value of CW and CCW.

Operation Type	CW / CCW
Wheel Mode	both are 0
Joint Mode	neither at 0
Multi-turn Mode	both are 4095

The wheel mode can be used to wheel-type operation robots since motors of the robots spin infinitely.

The joint mode can be used to multi-joints robot since the robots can be controlled with specific angles.

Multi Turn Offset

Adjusts position (zeroing). This value gets included in Present Position (36).

Present position + multi-turn offset.

Initial value is 0 and range is from -24576 to 24576

A Dynamixel with a position of 2048 with an applied offset of 1024 outputs a Present position of 3072.

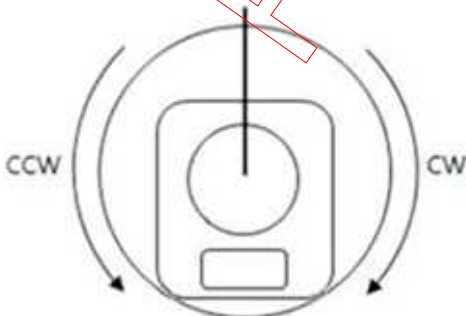

1. Real Position = 2048
2. Multi Turn Offset = 1024
3. Present Position = 3072

Note: This feature is only applied in multi-turn mode and ignored in other modes.

Resolution Divider

It allows the user to change Dynamixel's resolution.

The default Resolution Divider Value is set as 1. (1 ~ 4 available)

When resolution is lowered, revolutions (in both directions) can be increased (up to 28 turns in each direction).

Present Position = Real Position / Resolution Divider

For example, a Real Position of 2048 with a Resolution Divider set as 2 will yield a Present Position value of 1024 ($2048/2 = 1024$). A

Dynamixel with Resolution Divider set as 2 will have a resolution 2048 for a single revolution.

The Present Position can be obtained while Multi-turn Offset and Resolution Divider are taken into account.

Present position = (Real Position / Resolution Divider) + Multi-turn Offset

For example, a Dynamixel with a Real Position of 2048 with a Resolution Divider set as 4 and Multi-turn Offset as 1024 will yield a Present Position of 1535 ($(2048/4) + 1024 = 1535$).

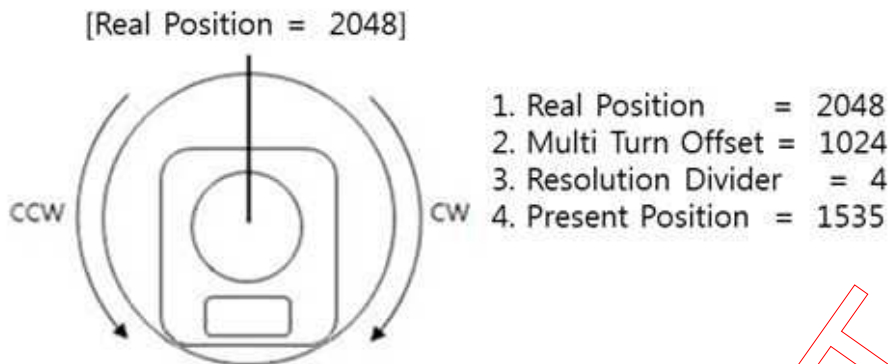

Note: This feature is only applied in multi-turn mode and ignored in other modes.

The Highest Limit Temperature

Caution : Do not set the temperature lower/higher than the default value.

When the temperature alarm shutdown occurs, wait 20 minutes to cool the temperature before re-use.

Using the product when the temperature is high may and can cause damage.

The Lowest (Highest) Limit Voltage

It is the operation range of voltage.

50 to 250 (0x32 ~ 0x96) can be used. The unit is 0.1V.

For example, if the value is 80, it is 8V.

If Present Voltage (Address42) is out of the range, Voltage Range Error Bit (Bit0) of Status Packet is returned as '1' and Alarm is triggered as set in the addresses 17 and 18.

Max Torque

It is the torque value of maximum output. 0 to 1023 (0x3FF) can be used, and the unit is about 0.1%.

For example, Data 1023 (0x3FF) means that Dynamixel will use 100% of the maximum torque it can produce while Data 512 (0x200) means that Dynamixel will use 50% of the maximum torque. When the power is turned on, Torque Limit (Addresses 34 and 35) uses the value as the initial value.

Status Return Level

It decides how to return Status Packet. There are three ways like the below table.

Value	Return of Status Packet
0	No return against all commands (Except PING Command)
1	Return only for the READ command
2	Return for all commands

When Instruction Packet is Broadcast ID, Status Packet is not returned regardless of Status Return Level.

Alarm LED

Alarm Shutdown

Dynamixel can protect itself by detecting errors occur during the operation.

The errors can be set are as the table below.

Bit	Name	Contents
Bit 7	0	-
Bit 6	Instruction Error	When undefined Instruction is transmitted or the Action command is delivered without the reg_write command
Bit 5	Overload Error	When the current load cannot be controlled with the set maximum torque
Bit 4	CheckSum Error	When the Checksum of the transmitted Instruction Packet is invalid
Bit 3	Range Error	When the command is given beyond the range of usage
Bit 2	OverHeating Error	When the internal temperature is out of the range of operating temperature set in the Control Table
Bit 1	Angle Limit Error	When Goal Position is written with the value that is not between CW Angle Limit and CCW Angle Limit
Bit 0	Input Voltage Error	When the applied voltage is out of the range of operating voltage set in the Control Table

It is possible to make duplicate set since the function of each bit is run by the logic of 'OR'. That is, if 0X05 (binary 00000101) is set, both Input Voltage Error and Overheating Error can be detected.

If errors occur, in case of Alarm LED, the LED blinks; in case of Alarm Shutdown, the motor output becomes 0 % by making the value of Torque Limit(Address 34, 35) as 0.

RAM Area

Torque Enable

Value	Meaning
0	Keeps Torque from generating by interrupting the power of motor.
1	Generates Torque by impressing the power to the motor.

LED

Bit	Meaning	Meaning
bit7		
bit6		
bit5		
bit4		
bit3		
bit2	BLUE LED	When <i>Bit</i> is set the blue LED turns on
bit1	GREEN LED	When <i>Bit</i> is set the green LED turns on
bit0	RED LED	When <i>Bit</i> is set the red LED turns on

PID Gain

MX series will use the PID controller as a main control method.

P gain refers to the value of proportional band.

I gain refers to the value of integral action.

D Gain refers to the value of derivative action.

Gains values are in between 0~254.

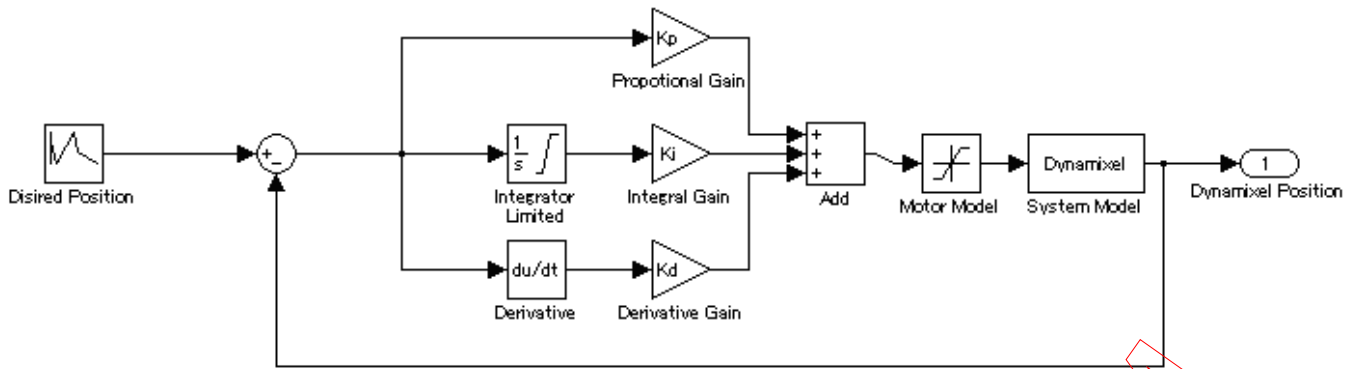

$$K_p = \text{P Gain} / 8$$

$$K_i = \text{I Gain} * 1000 / 2048$$

$$K_d = \text{D Gain} * 4 / 1000$$

※ The relationship between Compliance Slop and PID

Slope	P Gain
8	128
16	64
32	32
64	16
128	8

The less the P gain, The larger the back lash, and the weaker the amount of output near goal position.

At some extent, it is like a combined concept of margin and slope.

It does not exactly match the previous concept of compliance. So it is obvious if you see the difference in terms of motion.

※ Explanation for PID required.

For the brief explanation about general PID, please refer to the website(link) below.

http://en.wikipedia.org/wiki/PID_controller

FYI, PID control theory is not only limited to the control of motor(actuator) but is a generic theory that can be applied to all kinds of control.

Goal Position

It is a position value of destination.

0 to 4095 (0xFFFF) is available. The unit is 0.088 degree.

If Goal Position is out of the range, Angle Limit Error Bit (Bit1) of Status Packet is returned as '1' and Alarm is triggered as set in Alarm LED/Shutdown.

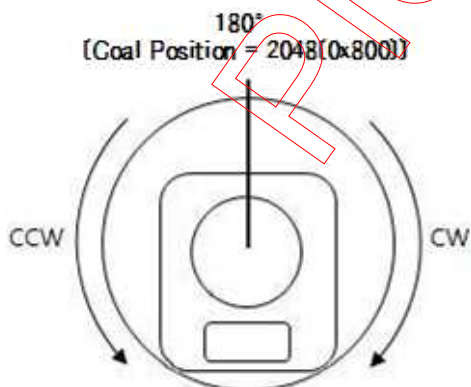

Moving Speed

- Joint Mode, Multi-Turn mode

It is a moving speed to Goal Position.

0~1023 (0X3FF) can be used, and the unit is about 0.114rpm.

If it is set to 0, it means the maximum rpm of the motor is used without controlling the speed.

If it is 1023, it is about 117.07rpm.

For example, if it is set to 300, it is about 34.33 rpm.

- Wheel Mode

It is a moving speed to Goal direction.

0~2047 (0X7FF) can be used, and the unit is about 0.114rpm.

If a value in the range of 0~1023 is used, it is stopped by setting to 0 while rotating to CCW direction.

If a value in the range of 1024~2047 is used, it is stopped by setting to 1024 while rotating to CW direction.

That is, the 10th bit becomes the direction bit to control the direction.

Note: This mode allows to check max rpm. Any values set higher than max rpm will not take effect.

Torque Limit

It is the value of the maximum torque limit.

0 to 1023 (0x3FF) is available, and the unit is about 0.1%.

For example, if the value is 512, it is about 50%; that means only 50% of the maximum torque will be used.

If the power is turned on, the value of Max Torque (Address 14, 15) is used as the initial value.

Notes: If the function of Alarm Shutdown is triggered, the motor loses its torque because the value becomes 0. At this moment, if the value is changed to the value other than 0, the motor can be used again.

Present Position

It is the current position value of Dynamixel.

The range of the value is 0~4095 (0xFFFF), and the unit is 0.088 degree.

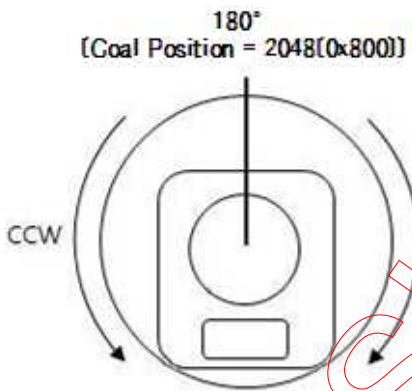

In multi-turn mode range is from -28672 to 28672 with unit values dependent on Resolution Divider (0.088 * Resolution Divider)

Note: in multi-turn mode Present position depends on resolution divider and multi-turn offset For more information turn to the section on [Multi Turn offset](#) and [Resolution Divider](#)

Present Speed

Is the current moving speed.

0~2047 (0x000~0X7FF) can be used.

If a value is in the range of 0~1023 then the motor rotates to the CCW direction.

If a value is in the range of 1024~2047 then the motor rotates to the CW direction.

The 10th bit becomes the direction bit to control the direction; 0 and 1024 are equal.

The value unit is about 0.11rpm.

For example, if it is set to 300 then the motor is moving to the CCW direction at a rate of about 34.33rpm.

Present Load

It means currently applied load.

The range of the value is 0~2047, and the unit is about 0.1%.

If the value is 0~1023, it means the load works to the CCW direction.

If the value is 1024~2047, it means the load works to the CW direction.

That is, the 10th bit becomes the direction bit to control the direction, and 1024 is equal to 0.

For example, the value is 512, it means the load is detected in the direction of CCW about 50% of the maximum torque.

BIT	15~11	10	9	8	7	6	5	4	3	2	1	0
Value	0	Load Direction	Data (Load Ratio)									

Load Direction = 0 : CCW Load, Load Direction = 1: CW Load

Notes: Current load is inferred from the internal torque value, not from Torque sensor etc.

For that reason, it cannot be used to measure weight or torque; however, it must be used only to detect which direction the force works.

Present Voltage

It is the size of the current voltage supplied.

This value is 10 times larger than the actual voltage. For example, when 10V is supplied, the data value is 100 (0x64).

Present Temperature

It is the internal temperature of Dynamixel in Celsius.

Data value is identical to the actual temperature in Celsius. For example, if the data value is 85 (0x55), the current internal temperature is 85°C.

Registered Instruction

Value	Meaning
0	There are no commands transmitted by REG_WRITE.
1	There are commands transmitted by REG_WRITE.

Notes: If ACTION command is executed, the value is changed into 0.

Moving

Value	Meaning
0	Goal position command execution is completed.
1	Goal position command execution is in progress.

Lock

Value	Meaning
0	EEPROM area can be modified.
1	EEPROM area cannot be modified.

Caution: If Lock is set to 1, the power must be turned off and then turned on again to change into 0.

Punch

Current to drive motor is at minimum.

Can choose vales from 0x00 to 0x3FF.

Current

Value at 2048(0x800) when current is consumption is idle.

Values higher than 2048(0x800) during positive current flow

Values lower than 2048(0x800) during negative current flow

The following is a method to calculate current flow

$$I = (4.5\text{mA}) * (\text{CURRENT} - 2048) \text{ in amps unit (A)}$$

For example, 68 gives a value of 2148, which corresponds to 450mA of current flow.

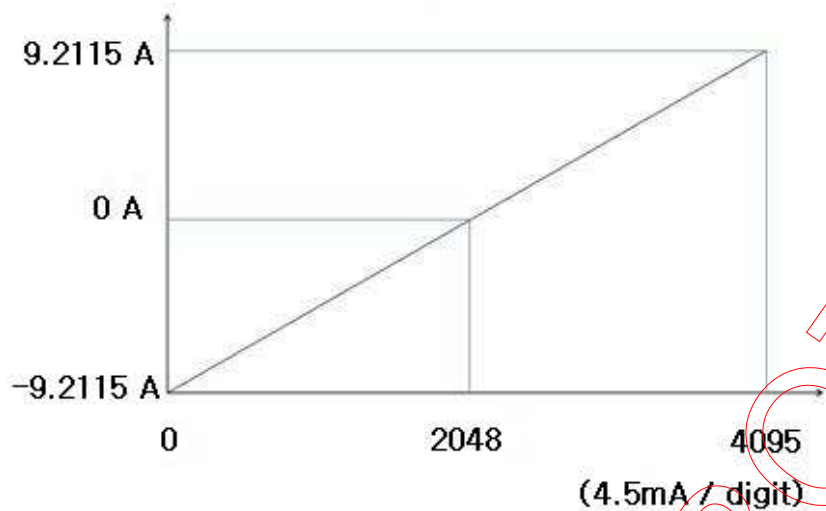

Torque Control Mode Enable

Value	Meaning
0	Turn off the torque mode. Executes Joint mode or Wheel mode.
1	Turn on the torque mode. Cannot control the position or moving speed but only Torque.

When Torque Control Mode Enable is at 1, DYNAMIXEL behaves like the followings

1. DYNAMIXEL does not control the position or the moving speed.
2. DYNAMIXEL controls with goal torque value.
3. DYNAMIXEL does not react to whatever value in Goal position and Goal speed.
4. Because position/moving speed is not controller, DYNAMIXEL behaves as if it is in the wheel mode.

Goal Torque

These are the goal torque value

You can use 0 ~ 2047 (0x7FF), and the unit is 4.5mA.

(torque is directly proportional to the current value.)

If you use from 0~1023, torque is on toward CCW, and when you set it to 0, it stops.

If you use from 1024~2047, torque is on toward CW, and when you set it to 1024, it stops.

That means, 10th bit becomes the direction bit, which controls direction.

Goal Torque cannot be bigger than Torque Limit(34,35)

Goal Acceleration

This is Goal Acceleration value.

It can be used from 0~254(0xFE), and the unit is approximately 8.583 Degree / sec².

When it is set to 0, there is no control over acceleration and moves with the maximum acceleration of the motor.

When the goal speed is set to 0, there is no control over acceleration and moves with the maximum acceleration of the motor.

When it is set to 254, it becomes 2180 Degree / sec²

For example, the current speed of Dynamixel is 0, and Goal acceleration is 10,

The speed of Dynamixel after 1 second will be 14.3 RPM.

Option Frame

The types of MX-64 option frame are as follows.

FR05-B101

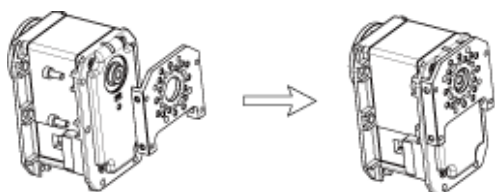

FR05-F101_FR05-X101

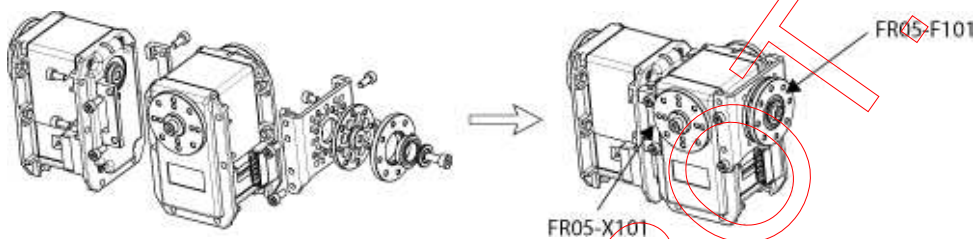

FR05-H101

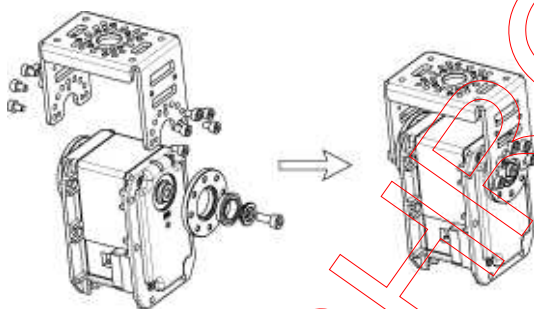

FR05-S101

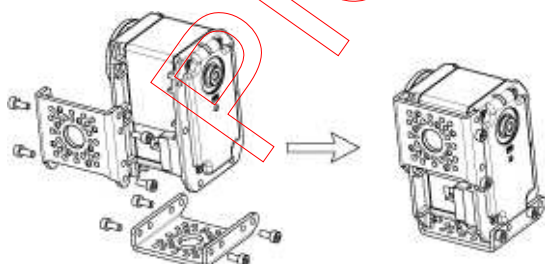

Horn

The types of MX-64 Horn are as follows.

HN05-N102



HN05-I101

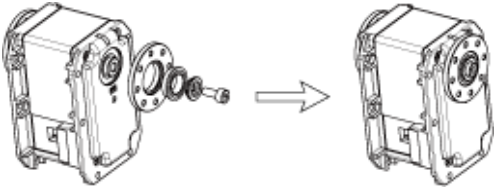

Ref: place careful attention when aligning the horn of the RX-64 to prevent misalignment.

Combination

The following example shows the combination structure of option frames and horns.

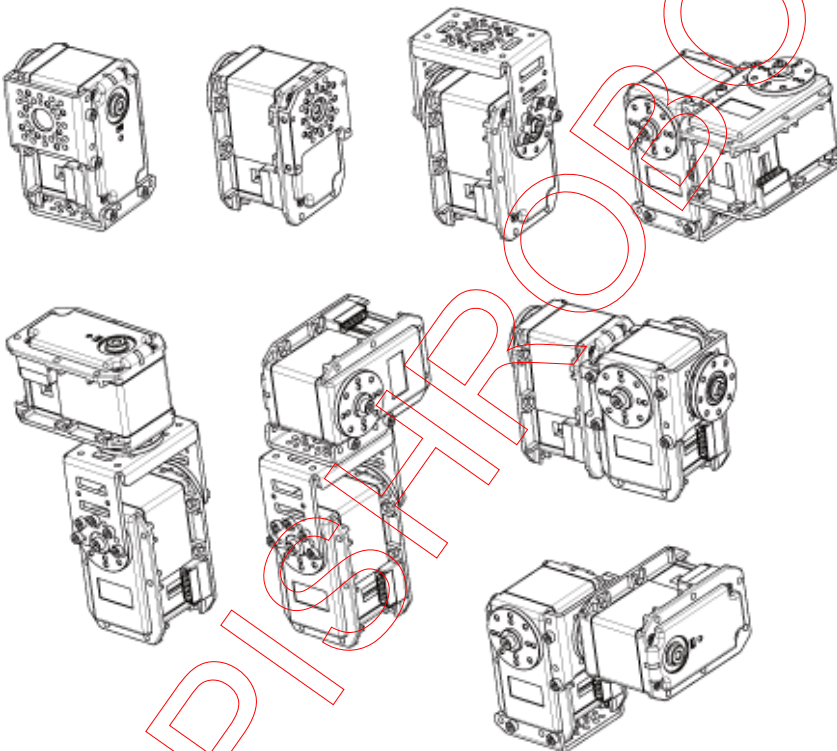

Dimension

Drawing Information : [DOWNLOAD](#) RX64Dimension.pdf

Videos

HOW TO REPLACE GEARS