

SRF08 Ultra sonic range finder

Technical Specification

Communication with the SRF08 ultrasonic rangefinder is via the I2C bus. This is available on popular controllers such as the OOPic and Stamp BS2p, as well as a wide variety of micro-controllers. To the programmer the SRF08 behaves in the same way as the ubiquitous 24xx series eeprom's, except that the I2C address is different. The default shipped address of the SRF08 is 0xE0. It can be changed by the user to any of 16 addresses E0, E2, E4, E6, E8, EA, EC, EE, F0, F2, F4, F6, F8, FA, FC or FE, therefore up to 16 sonar's can be used. In addition to the above addresses, all sonar's on the I2C bus will respond to address 0 - the General Broadcast address. This means that writing a ranging command to I2C address 0 (0x00) will start all sonar's ranging at the same time. This should be useful in ANN Mode (See below). The results must be read individually from each sonar's real address. We have [examples](#) of using the SRF08 module with a wide range of popular controllers.

Connections

The "Do Not Connect" pin should be left unconnected. It is actually the CPU MCLR line and is used once only in our workshop to program the PIC16F872 on-board after assembly, and has an internal pull-up resistor. The SCL and SDA lines should each have a pull-up resistor to +5v somewhere on the I2C bus. You only need one pair of resistors, not a pair for every module. They are normally located with the bus master rather than the slaves. The SRF08 is always a slave - never a bus master. If you need them, I recommend 1.8k resistors. Some modules such as the OOPic already have pull-up resistors and you do not need to add any more.

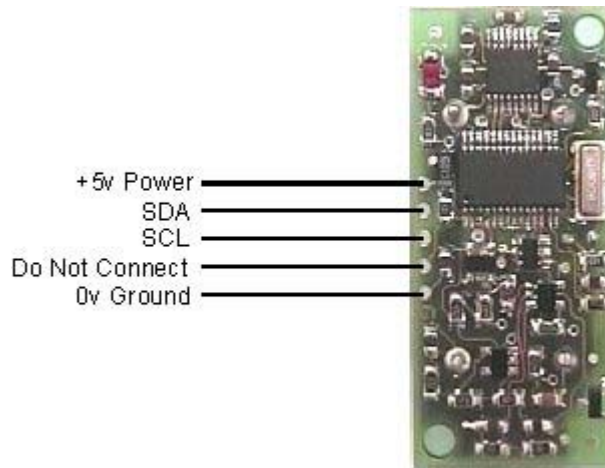

Registers

The SRF08 appears as a set of 36 registers.

Location	Read	Write
0	Software Revision	Command Register
1	Light Sensor	Max Gain Register (default 31)
2	1st Echo High Byte	Range Register (default 255)
3	1st Echo Low Byte	N/A
~~~~	~~~~	~~~~
34	17th Echo High	N/A

	Byte	
35	17th Echo Low Byte	N/A

Only locations 0, 1 and 2 can be written to. Location 0 is the command register and is used to start a ranging session. It cannot be read. Reading from location 0 returns the SRF08 software revision. By default, the ranging lasts for 65mS, but can be changed by writing to the range register at location 2. If you do so, then you will likely need to change the analogue gain by writing to location 1. See the **Changing Range** and **Analogue Gain** sections below.

Location 1 is the onboard light sensor. This data is updated every time a new ranging command has completed and can be read when range data is read. The next two locations, 2 and 3, are the 16bit unsigned result from the latest ranging - high byte first. The meaning of this value depends on the command used, and is either the range in inches, or the range in cm or the flight time in uS. A value of zero indicates that no objects were detected. There are up to a further 16 results indicating echo's from more distant objects.

### Commands

There are three commands to initiate a ranging (80 to 82), to return the result in inches, centimeters or microseconds. There is also an ANN mode (Artificial Neural Network) mode which is described later and a set of commands to change the I2C address.

Command		Action
Decimal	Hex	
80	0x50	Ranging Mode - Result in inches
81	0x51	Ranging Mode - Result in centimeters
82	0x52	Ranging Mode - Result in micro-seconds
83	0x53	ANN Mode - Result in inches
84	0x54	ANN Mode - Result in centimeters
85	0x55	ANN Mode - Result in micro-seconds
160	0xA0	1st in sequence to change I2C address
165	0xA5	3rd in sequence to change I2C address
170	0xAA	2nd in sequence to change I2C address

### Ranging Mode

To initiate a ranging, write one of the above commands to the command register and wait the required amount of time for completion and read as many results as you wish. The echo buffer is cleared at the start of each ranging. The first echo range is placed in locations 2,3. the second in 4,5, etc. If a location (high and low bytes) is 0, then there will be no further reading in the rest of the registers. The default and recommended time for completion of ranging is 65mS, however you can shorten this by writing to the range register before issuing a ranging command. Light sensor data at location 1 will also have been updated after a ranging command.

### ANN Mode

ANN mode (Artificial Neural Network) is designed to provide the multi echo data in a way that is easier to input to a neural network, at least I hope it is - I've not actually done it yet. ANN mode provides a 32 byte buffer (locations 4 to 35 inclusive) where each byte represents the 65536uS maximum flight time divided into 32 chunks of 2048uS each - equivalent to about 352mm of range. If an echo is received within a bytes time slot then it will be set to no-zero, otherwise it will be zero. So if an echo is received from within the first 352mm,

location 4 will be non-zero. If an object is detected 3m away the location 12 will be non-zero ( $3000/352 = 8$ ) ( $8+4=12$ ). Arranging the data like this should be better for a neural net than the other formats. The input to your network should be 0 if the byte is zero and 1 if its non-zero. I have a SOFM (Self Organizing Feature Map) in mind for the neural net, but will hopefully be useful for any type.

Location 4	Location 5	Location 6	Location 7	Locations 8 - 35
0 - 352mm	353 - 705mm	706 - 1057mm	1058 - 1410mm	and so on

Locations 2,3 contain the range of the nearest object converted to inches, cm or uS and is the same as for Ranging Mode.

### Checking for Completion of Ranging

You do not have to use a timer on your own controller to wait for ranging to finish. You can take advantage of the fact that the SRF08 will not respond to any I2C activity whilst ranging. Therefore, if you try to read from the SRF08 (we use the software revision number a location 0) then you will get 255 (0xFF) whilst ranging. This is because the I2C data line (SDA) is pulled high if nothing is driving it. As soon as the ranging is complete the SRF08 will again respond to the I2C bus, so just keep reading the register until its not 255 (0xFF) anymore. You can then read the sonar data. Your controller can take advantage of this to perform other tasks while the SRF08 is ranging.

### Changing the Range

The maximum range of the SRF08 is set by an internal timer. By default, this is 65mS or the equivalent of 11 metres of range. This is much further than the 6 metres the SRF08 is actually capable of. It is possible to reduce the time the SRF08 listens for an echo, and hence the range, by writing to the range register at location 2. The range can be set in steps of about 43mm (0.043m or 1.68 inches) up to 11 metres.

The range is  $((\text{Range Register} \times 43\text{mm}) + 43\text{mm})$  so setting the Range Register to 0 (0x00) gives a maximum range of 43mm. Setting the Range Register to 1 (0x01) gives a maximum range of 86mm. More usefully, 24 (0x18) gives a range of 1 metre and 140 (0x8C) is 6 metres. Setting 255 (0xFF) gives the original 11 metres ( $255 \times 43 + 43$  is 11008mm). There are two reasons you may wish to reduce the range.

1. To get at the range information quicker
2. To be able to fire the SRF08 at a faster rate.

If you only wish to get at the range information a bit sooner and will continue to fire the SRF08 at 65ms of slower, then all will be well. However if you wish to fire the SRF08 at a faster rate than 65mS, you will definitely need to reduce the gain - see next section.

The range is set to maximum every time the SRF08 is powered-up. If you need a different range, change it once as part of your system initialization code.

### Analogue Gain

The analogue gain register sets the *Maximum* gain of the analogue stages. To set the maximum gain, just write one of these values to the gain register at location 1. During a ranging, the analogue gain starts off at its minimum value of 94. This is increased at approx. 70uS intervals up to the maximum gain setting, set by register 1. Maximum possible gain is reached after about 390mm of range. The purpose of providing a limit to the maximum gain is to allow you to fire the sonar more rapidly than 65mS. Since the ranging can be very short, a new ranging can be initiated as soon as the previous range data has been read. A potential hazard with this is that the second ranging may pick up a distant echo returning from the previous "ping", give a false result of a close by object when there is none. To reduce this possibility, the maximum gain can be reduced to limit the modules sensitivity to the weaker distant echo, whilst still able to detect close by objects. The maximum gain setting is stored only in the CPU's RAM and is initialized to maximum on power-up, so if you only want

do a ranging every 65mS, or longer, you can ignore the Range and Gain Registers.

**Note** - Effective in Ranging Mode only, in ANN mode, gain is controlled automatically.

Gain Register		Maximum Analogue Gain
Decimal	Hex	
0	0x00	Set Maximum Analogue Gain to 94
1	0x01	Set Maximum Analogue Gain to 97
2	0x02	Set Maximum Analogue Gain to 100
3	0x03	Set Maximum Analogue Gain to 103
4	0x04	Set Maximum Analogue Gain to 107
5	0x05	Set Maximum Analogue Gain to 110
6	0x06	Set Maximum Analogue Gain to 114
7	0x07	Set Maximum Analogue Gain to 118
8	0x08	Set Maximum Analogue Gain to 123
9	0x09	Set Maximum Analogue Gain to 128
10	0x0A	Set Maximum Analogue Gain to 133
11	0x0B	Set Maximum Analogue Gain to 139
12	0x0C	Set Maximum Analogue Gain to 145
13	0x0D	Set Maximum Analogue Gain to 152
14	0x0E	Set Maximum Analogue Gain to 159
15	0x0F	Set Maximum Analogue Gain to 168
16	0x10	Set Maximum Analogue Gain to 177
17	0x11	Set Maximum Analogue Gain to 187
18	0x12	Set Maximum Analogue Gain to 199
19	0x13	Set Maximum Analogue Gain to 212
20	0x14	Set Maximum Analogue Gain to 227
21	0x15	Set Maximum Analogue Gain to 245
22	0x16	Set Maximum Analogue Gain to 265
23	0x17	Set Maximum Analogue Gain to 288
24	0x18	Set Maximum Analogue Gain to 317
25	0x18	Set Maximum Analogue Gain to 352
26	0x20	Set Maximum Analogue Gain to 395
27	0x21	Set Maximum Analogue Gain to 450
28	0x22	Set Maximum Analogue Gain to 524
29	0x23	Set Maximum Analogue Gain to 626
30	0x24	Set Maximum Analogue Gain to 777
31	0x25	Set Maximum Analogue Gain to 1025

Note that the relationship between the Gain Register setting and the actual gain is not a linear one. Also there is no magic formula to say "use this gain setting with that range setting". It depends on the size, shape and material of the object and what else is around in the room. Try playing with different settings until you get the result you want. If you appear to get false readings, it may be echo's from previous "pings", try going back to firing the SRF08 every 65mS or longer (slower).

If you are in any doubt about the Range and Gain Registers, remember they are automatically set by the SRF08 to their default values when it is powered-up. You can ignore and forget about them and the SRF08 will work

fine, detecting objects up to 6 metres away every 65mS or slower.

### Light Sensor

The SRF08 has a light sensor on-board. A reading of the light intensity is made by the SRF08 each time a ranging takes place in either Ranging or ANN Modes ( The A/D conversion is actually done just before the "ping" whilst the +/- 10v generator is stabilizing). The reading increases as the brightness increases, so you will get a maximum value in bright light and minimum value in darkness. It should get close to 2-3 in complete darkness and up to about 248 (0xF8) in bright light. The light intensity can be read from the Light Sensor Register at location 1 at the same time that you are reading the range data.

### LED

The red LED is used to flash out a code for the I2C address on power-up (see below). It also gives a brief flash during the "ping" whilst ranging.

### Changing the I2C Bus Address

To change the I2C address of the SRF08 you must have only one sonar on the bus. Write the 3 sequence commands in the correct order followed by the address. Example; to change the address of a sonar currently at 0xE0 (the default shipped address) to 0xF2, write the following to address 0xE0; (0xA0, 0xAA, 0xA5, 0xF2 ). These commands must be sent in the correct sequence to change the I2C address, additionally, No other command may be issued in the middle of the sequence. The sequence must be sent to the command register at location 0, which means 4 separate write transactions on the I2C bus. When done, you should label the sonar with its address, however if you do forget, just power it up without sending any commands. The SRF08 will flash its address out on the LED. One long flash followed by a number of shorter flashes indicating its address. The flashing is terminated immediately on sending a command the SRF08.

Address		Long Flash	Short flashes
Decimal	Hex		
224	E0	1	0
226	E2	1	1
228	E4	1	2
230	E6	1	3
232	E8	1	4
234	EA	1	5
236	EC	1	6
238	EE	1	7
240	F0	1	8
242	F2	1	9
244	F4	1	10
246	F6	1	11
248	F8	1	12
250	FA	1	13
252	FC	1	14
254	FE	1	15

Take care not to set more than one sonar to the same address, there will be a bus collision and very unpredictable results.

### Current Consumption

Average current consumption measured on our prototype is around 12mA during ranging, and 3mA standby. The module will automatically go to standby mode after a ranging, whilst waiting for a new command on the I2C bus. The actual measured current profile is as follows;

Operation	Current	Duration
Ranging command received - Power on	275mA	3uS
+/- 10v generator Stabilization	25mA	600uS
8 cycles of 40kHz "ping"	40mA	200uS
Ranging	11mA	65mS max
Standby	3mA	indefinite

The above values are for guidance only, they are not tested on production units.

### Changing beam pattern and beam width

You can't! This is a question which crops up regularly, however there is no easy way to reduce or change the beam width that I'm aware of. The beam pattern of the SRF08 is conical with the width of the beam being a function of the surface area of the transducers and is fixed. The beam pattern of the transducers used on the SRF08, taken from the manufacturers data sheet, is shown below.

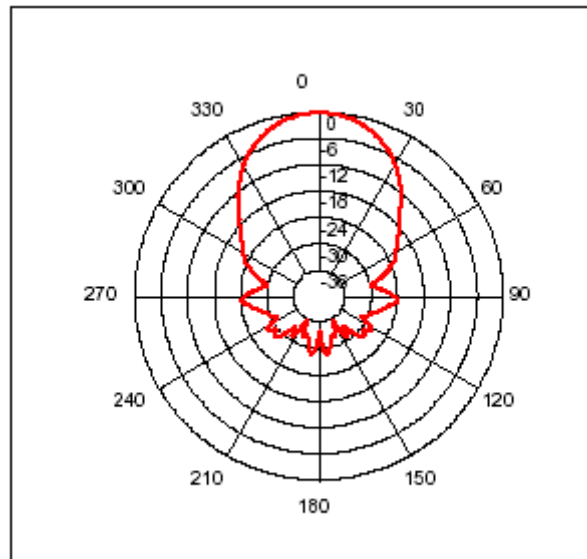

There is more information in the [sonar faq](#). Here you can have a look at the [schematic](#) and [software](#)

Your feedback/comments/criticisms and wish lists are very welcome, as always.