

RX-64

Parts Photo



[RX-64]

H/W Specification

- Weight : 125g
- Dimension : 40.2mm x 61.1mm x 41mm
- Resolution : 0.29°
- Gear Reduction Ratio: 200 : 1
- Stall Torque : 5.3N.m (at 18.5V, 2.6A)
- No load speed : 64rpm (at 18.5V)
- Running Degree
 - 0° ~ 300°
 - Endless Turn
- Running Temperature : -5°C ~ +80°C
- Voltage : 12 ~ 18.5V (Recommended Voltage 14.8V)
- Command Signal : Digital Packet
- Protocol Type : RS485 Asynchronous Serial Communication (8bit,1stop, No Parity)
- Link (Physical) : RS485 Multi Drop Bus
- ID : 254 ID (0~253)
- Communication Speed : 7343bps ~ 1 Mbps
- Feedback : Position, Temperature, Load, Input Voltage, etc.
- Material : Full Metal Gear, Engineering Plastic Body
- Standby current : 50 mA

Control Table

Control Table consists of data regarding the current status and operation, which exists inside of Dynamixel. The user can control Dynamixel by changing data of Control Table via Instruction Packet.

EEPROM and RAM

Data in RAM area is reset to the initial value whenever the power is turned on while data in EEPROM area is kept once the value is set even if the power is turned off.

Address

It represents the location of data. To read from or write data to Control Table, the user should assign the correct address in the Instruction Packet.

Access

Dynamixel has two kinds of data: Read-only data, which is mainly used for sensing, and Read-and-Write data, which is used for driving.

Initial Value

In case of data in the EEPROM Area, the initial values on the right side of the below Control Table are the factory default settings. In case of data in the RAM Area, the initial values on the right side of the above Control Tables are the ones when the power is turned on.

Highest/Lowest Byte

In the Control table, some data share the same name, but they are attached with (L) or (H) at the end of each name to distinguish the address. This data requires 16bit, but it is divided into 8bit each for the addresses (low) and (high). These two addresses should be written with one Instruction Packet at the same time.

Area	Address (Hexadecimal)	Name	Description	Access	Initial Value (Hexadecimal)
	0 (0X00)	Model Number(L)	Lowest byte of model number	R	64 (0X40)
	1 (0X01)	Model Number(H)	Highest byte of model number	R	0 (0X00)

E E P R O M	2 (0X02)	Version of Firmware	Information on the version of firmware	R	-	
	3 (0X03)	ID	ID of Dynamixel	RW	1 (0X01)	
	4 (0X04)	Baud Rate	Baud Rate of Dynamixel	RW	34 (0X22)	
	5 (0X05)	Return Delay Time	Return Delay Time	RW	250 (0XFA)	
	6 (0X06)	CW Angle Limit(L)	Lowest byte of clockwise Angle Limit	RW	0 (0X00)	
	7 (0X07)	CW Angle Limit(H)	Highest byte of clockwise Angle Limit	RW	0 (0X00)	
	8 (0X08)	CCW Angle Limit(L)	Lowest byte of counterclockwise Angle Limit	RW	255 (0XFF)	
	9 (0X09)	CCW Angle Limit(H)	Highest byte of counterclockwise Angle Limit	RW	3 (0X03)	
	11 (0X0B)	the Highest Limit Temperature	Internal Limit Temperature	RW	80 (0X50)	
	12 (0X0C)	the Lowest Limit Voltage	Lowest Limit Voltage	RW	60 (0X3C)	
	13 (0X0D)	the Highest Limit Voltage	Highest Limit Voltage	RW	240 (0XF0)	
	14 (0X0E)	Max Torque(L)	Lowest byte of Max. Torque	RW	255 (0XFF)	
	15 (0X0F)	Max Torque(H)	Highest byte of Max. Torque	RW	3 (0X03)	
	16 (0X10)	Status Return Level	Status Return Level	RW	2 (0X02)	
	17 (0X11)	Alarm LED	LED for Alarm	RW	36 (0X24)	
	18 (0X12)	Alarm Shutdown	Shutdown for Alarm	RW	36 (0X24)	
	R A M	24 (0X18)	Torque Enable	Torque On/Off	RW	0 (0X00)
		25 (0X19)	LED	LED On/Off	RW	0 (0X00)
26 (0X1A)		CW Compliance Margin	CW Compliance margin	RW	1 (0X01)	
27 (0X1B)		CCW Compliance Margin	CCW Compliance margin	RW	1 (0X01)	
28 (0X1C)		CW Compliance Slope	CW Compliance slope	RW	32 (0X20)	
29 (0X1D)		CCW Compliance Slope	CCW Compliance slope	RW	32 (0X20)	
30 (0X1E)		Goal Position(L)	Lowest byte of Goal Position	RW	-	
31 (0X1F)		Goal Position(H)	Highest byte of Goal Position	RW	-	
32 (0X20)		Moving Speed(L)	Lowest byte of Moving Speed	RW	-	
33 (0X21)		Moving Speed(H)	Highest byte of Moving Speed	RW	-	
34 (0X22)		Torque Limit(L)	Lowest byte of Torque Limit	RW	ADD14	
35 (0X23)		Torque Limit(H)	Highest byte of Torque Limit	RW	ADD15	
36 (0X24)		Present Position(L)	Lowest byte of Current Position	R	-	
37 (0X25)		Present Position(H)	Highest byte of Current Position	R	-	
38 (0X26)		Present Speed(L)	Lowest byte of Current Speed	R	-	
39 (0X27)		Present Speed(H)	Highest byte of Current Speed	R	-	
40 (0X28)		Present Load(L)	Lowest byte of Current Load	R	-	
41 (0X29)		Present Load(H)	Highest byte of Current Load	R	-	
42 (0X2A)		Present Voltage	Current Voltage	R	-	
43 (0X2B)		Present Temperature	Current Temperature	R	-	
44 (0X2C)		Registered	Means if Instruction is registered	RW	0 (0X00)	
46 (0X2E)	Moving	Means if there is any movement	R	0 (0X00)		
47 (0X2F)	Lock	Locking EEPROM	RW	0 (0X00)		
48 (0X30)	Punch(L)	Lowest byte of Punch	RW	32 (0X20)		
49 (0X31)	Punch(H)	Highest byte of Punch	RW	0 (0X00)		

Address Function Help

EEPROM Area

Model Number

It represents the Model Number.

Firmware Version

It represents the firmware version.

ID

It is a unique number to identify Dynamixel.

The range from 0 to 253 (0xFD) can be used, and, especially, 254(0xFE) is used as the Broadcast ID.

If the Broadcast ID is used to transmit Instruction Packet, we can command to all Dynamixels.

Please be careful not to duplicate the ID of connected Dynamixel.

Baud Rate

It represents the communication speed. 0 to 254 (0xFE) can be used for it.

This speed is calculated by using the below formula.

$$\text{Speed(BPS)} = 2000000 / (\text{Data} + 1)$$

Data	Set BPS	Target BPS	Tolerance
1	1000000.0	1000000.0	0.000 %
3	500000.0	500000.0	0.000 %
4	400000.0	400000.0	0.000 %
7	250000.0	250000.0	0.000 %
9	200000.0	200000.0	0.000 %
16	117647.1	115200.0	-2.124 %
34	57142.9	57600.0	0.794 %
103	19230.8	19200.0	-0.160 %
207	9615.4	9600.0	-0.160 %

Note : Maximum Baud Rate error of 3% is within the tolerance of UART communication.

Return Delay Time

It is the delay time per data value that takes from the transmission of Instruction Packet until the return of Status Packet.

0 to 254 (0xFE) can be used, and the delay time per data value is 2 usec.

That is to say, if the data value is 10, 20 usec is delayed. The initial value is 250 (0xFA) (i.e., 0.5 msec).

CW/CCW Angle Limit

The angle limit allows the motion to be restrained.

The range and the unit of the value is the same as Goal Position(Address 30, 31).

- CW Angle Limit: the minimum value of Goal Position(Address 30, 31)
- CCW Angle Limit: the maximum value of Goal Position(Address 30, 31)

The following two modes can be set pursuant to the value of CW and CCW.

Operation Type	CW / CCW
Wheel Mode	the value of the both are 0
Joint Mode	the value of the both are not 0

The wheel mode can be used to wheel-type operation robots since motors of the robots spin infinitely.

The joint mode can be used to multi-joints robot since the robots can be controlled with specific angles.

The Highest Limit Temperature

It is the highest limit of operating temperature.

The range for use is 10 to 99 (0x10~0x63). The unit is Celsius.

For example, if the value is 80, it is 80°C.

If the internal temperature of Dynamixel exceeds this range, Over Heating Error Bit (Bit2) of Status Packet is returned as '1' and Alarm is triggered as set in the addresses 17 and 18.

Caution : Do not set the temperature lower/higher than the default value.

When the temperature alarm shutdown occurs, wait 20 minutes to cool the temperature before re-use.

Using the product when the temperature is high may and can cause damage.

The Lowest (Highest) Limit Voltage

It is the operation range of voltage.

50 to 250 (0x32 ~ 0x96) can be used. The unit is 0.1V.

For example, if the value is 80, it is 8V.

If Present Voltage (Address42) is out of the range, Voltage Range Error Bit (Bit0) of Status Packet is returned as '1' and Alarm is triggered as set in the addresses 17 and 18.

Max Torque

It is the torque value of maximum output. 0 to 1023 (0x3FF) can be used, and the unit is about 0.1%.

For example, Data 1023 (0x3FF) means that Dynamixel will use 100% of the maximum torque it can produce while Data 512 (0x200) means that Dynamixel will use 50% of the maximum torque. When the power is turned on, Torque Limit (Addresses 34 and 35) uses the value as the initial value.

Status Return Level

It decides how to return Status Packet. There are three ways like the below table.

Value	Return of Status Packet
0	No return against all commands (Except PING Command)
1	Return only for the READ command
2	Return for all commands

When Instruction Packet is Broadcast ID, Status Packet is not returned regardless of Status Return Level.

Alarm LED

Alarm Shutdown

Dynamixel can protect itself by detecting errors occur during the operation.

The errors can be set are as the table below.

Bit	Name	Contents
Bit 7	0	-
Bit 6	Instruction Error	When undefined Instruction is transmitted or the Action command is delivered without the reg_write command
Bit 5	Overload Error	When the current load cannot be controlled with the set maximum torque
Bit 4	CheckSum Error	When the Checksum of the transmitted Instruction Packet is invalid
Bit 3	Range Error	When the command is given beyond the range of usage
Bit 2	OverHeating Error	When the internal temperature is out of the range of operating temperature set in the Control Table
Bit 1	Angle Limit Error	When Goal Position is written with the value that is not between CW Angle Limit and CCW Angle Limit
Bit 0	Input Voltage Error	When the applied voltage is out of the range of operating voltage set in the Control Table

It is possible to make duplicate set since the function of each bit is run by the logic of 'OR'. That is, if 0X05 (binary 00000101) is set, both Input Voltage Error and Overheating Error can be detected.

If errors occur, in case of Alarm LED, the LED blinks; in case of Alarm Shutdown, the motor output becomes 0 % by making the value of Torque Limit(Address 34, 35) as 0.

RAM Area

Torque Enable

Value	Meaning
0	Keeps Torque from generating by interrupting the power of motor.
1	Generates Torque by impressing the power to the motor.

LED

Value	Meaning
0	Turn OFF the LED.
1	Turn ON the LED.

Compliance

Compliance is to set the control flexibility of the motor.

The following diagram shows the relationship between output torque and position of the motor.

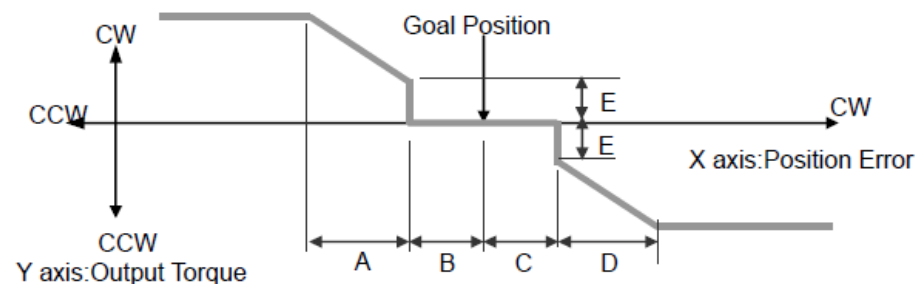

- A : CCW Compliance Slope(Address0x1D)
- B : CCW Compliance Margin(Address0x1B)
- C : CW Compliance Margin(Address0x1A)
- D : CW Compliance Slope (Address0x1C)
- E : Punch(Address0x30,31)

Compliance Margin

It exists in each direction of CW/CCW and means the error between goal position and present position.

The range of the value is 0~255, and the unit is the same as Goal Position.(Address 30,31)

The greater the value, the more difference occurs.

Compliance Slope

It exists in each direction of CW/CCW and sets the level of Torque near the goal position.

Compliance Slope is set in 7 steps, the higher the value, the more flexibility is obtained.

Data representative value is actually used value. That is, even if the value is set to 25, 16 is used internally as the representative value.

Step	Data Value	Data Representative Value
1	0 (0x00) ~ 3(0x03)	2 (0x02)
2	4(0x04) ~ 7(0x07)	4 (0x04)
3	8(0x08)~15(0x0F)	8 (0x08)
4	16(0x10)~31(0x1F)	16 (0x10)
5	32(0x20)~63(0x3F)	32 (0x20)
6	64(0x40)~127(0x7F)	64 (0x40)
7	128(0x80)~254(0xFE)	128 (0x80)

Goal Position

It is a position value of destination.

0 to 1023 (0x3FF) is available. The unit is 0.29 degree.

If Goal Position is out of the range, Angle Limit Error Bit (Bit1) of Status Packet is returned as '1' and Alarm is triggered as set in Alarm LED/Shutdown.

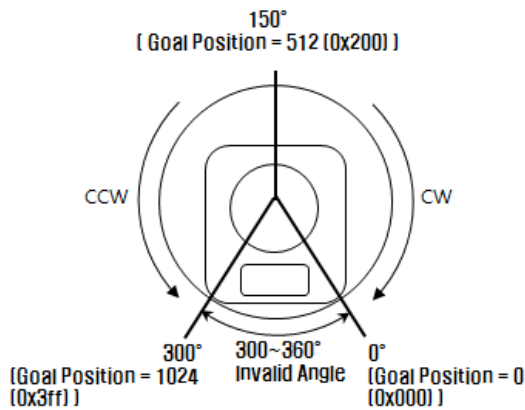

If it is set to Wheel Mode, this value is not used.

Moving Speed

It is a moving speed to Goal Position.

The range and the unit of the value may vary depending on the operation mode.

- Join Mode
0~1023 (0X3FF) can be used, and the unit is about 0.111rpm.
If it is set to 0, it means the maximum rpm of the motor is used without controlling the speed.
If it is 1023, it is about 114rpm.
For example, if it is set to 300, it is about 33.3 rpm.

Notes: Please check the maximum rpm of relevant model in Joint Mode. Even if the motor is set to more than maximum rpm, it cannot generate the torque more than the maximum rpm.

- Wheel Mode
0~2047(0X7FF) can be used, the unit is about 0.1%.
If a value in the range of 0~1023 is used, it is stopped by setting to 0 while rotating to CCW direction.
If a value in the range of 1024~2047 is used, it is stopped by setting to 1024 while rotating to CW direction.
That is, the 10th bit becomes the direction bit to control the direction.

In Wheel Mode, only the Torque control is possible, not speed.

For example, if it is set to 512, it means the torque is controlled by 50% of the maximum torque.

Torque Limit

It is the value of the maximum torque limit.

0 to 1023 (0x3FF) is available, and the unit is about 0.1%.

For example, if the value is 512, it is about 50%: that means only 50% of the maximum torque will be used.

If the power is turned on, the value of Max Torque (Address 14, 15) is used as the initial value.

Notes: If the function of Alarm Shutdown is triggered, the motor loses its torque because the value becomes 0. At this moment, if the value is changed to the value other than 0, the motor can be used again.

Present Position

It is the current position value of Dynamixel.

The range of the value is 0~1023 (0x3FF), and the unit is 0.29 degree.

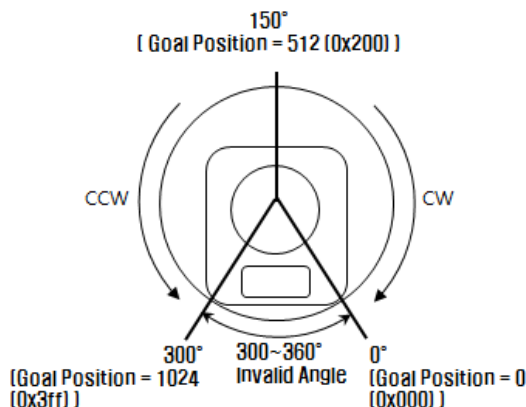

<The picture above is based on the front of relevant model>

Caution: If it is set to Wheel Mode, the value cannot be used to measure the moving distance and the rotation frequency.

Present Speed

It is the current moving speed.

0~2047 (0x7FF) can be used.

If a value is in the range of 0~1023, it means that the motor rotates to the CCW direction.

If a value is in the range of 1024~2047, it means that the motor rotates to the CW direction.

That is, the 10th bit becomes the direction bit to control the direction, and 0 and 1024 are equal.

The unit of this value varies depending on operation mode.

- Joint Mode
 - The unit is about 0.111rpm.
 - For example, if it is set to 300, it means that the motor is moving to the CCW direction at a rate of about 33.3rpm.
- Wheel Mode
 - The unit is about 0.1%.
 - For example, if it is set to 512, it means that the torque is controlled by 50% of the maximum torque to the CCW direction.

Present Load

It means currently applied load.

The range of the value is 0~2047, and the unit is about 0.1%.

If the value is 0~1023, it means the load works to the CCW direction.

If the value is 1024~2047, it means the load works to the CW direction.

That is, the 10th bit becomes the direction bit to control the direction, and 1024 is equal to 0.

For example, the value is 512, it means the load is detected in the direction of CCW about 50% of the maximum torque.

BIT	15~11	10	9	8	7	6	5	4	3	2	1	0
Value	0	Load Direction	Data (Load Ratio)									

Load Direction = 0 : CCW Load, Load Direction = 1: CW Load

Notes: Current load is inferred from the internal torque value, not from Torque sensor etc.
For that reason, it cannot be used to measure weight or torque; however, it must be used only to detect which direction the force works.

Present Voltage

It is the size of the current voltage supplied.

This value is 10 times larger than the actual voltage. For example, when 10V is supplied, the data value is 100 (0x64)

Present Temperature

It is the internal temperature of Dynamixel in Celsius.

Data value is identical to the actual temperature in Celsius. For example, if the data value is 85 (0x55), the current internal temperature is 85°C.

Registered Instruction

Value	Meaning
0	There are no commands transmitted by REG_WRITE
1	There are commands transmitted by REG_WRITE.

Notes: If ACTION command is executed, the value is changed into 0.

Moving

Value	Meaning
0	Goal position command execution is completed.
1	Goal position command execution is in progress.

Lock

Value	Meaning
0	EEPROM area can be modified.
1	EEPROM area cannot be modified.

Caution: If Lock is set to 1, the power must be turned off and then turned on again to change into 0.

Punch

Current to drive motor is at minimum.

Can choose vales from 0x20 to 0x3FF.

Option Frame (Old Model)

The types of RX-64 option frame are as follows.

FR05-B1(OF-64B)

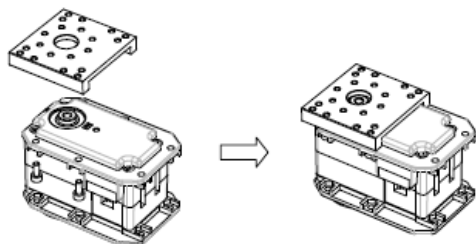

FR05-H1(OF-64H)

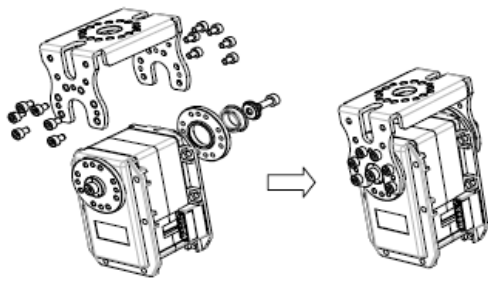

FR05-S1(OF-64S)

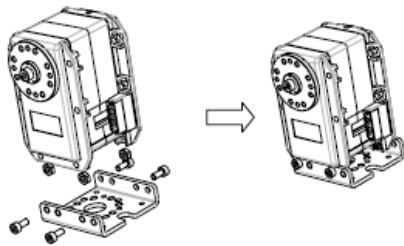
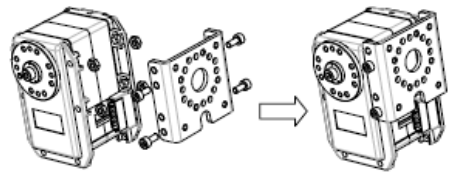

FR05-S2(OF-64S2)

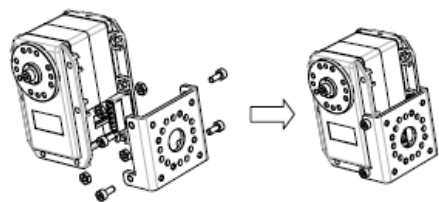

Horn (Old Model)

The types of RX-64 Horns are as follows.

HN05-N1(Horn RX-64)



HN05-I1(Bearing Set RX-64H)

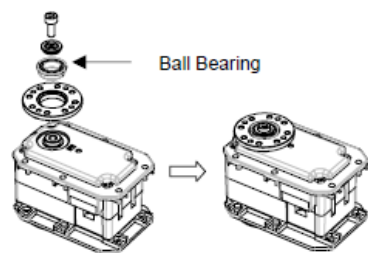

HN05-T1(Horn 64T Set)

PISHROBOT.COM

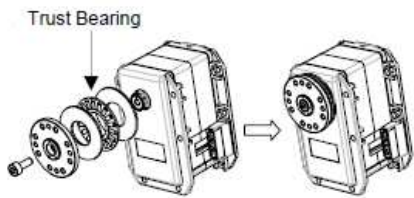

Combination (Old Model)

The following example shows the combination structure of option frames and horns.

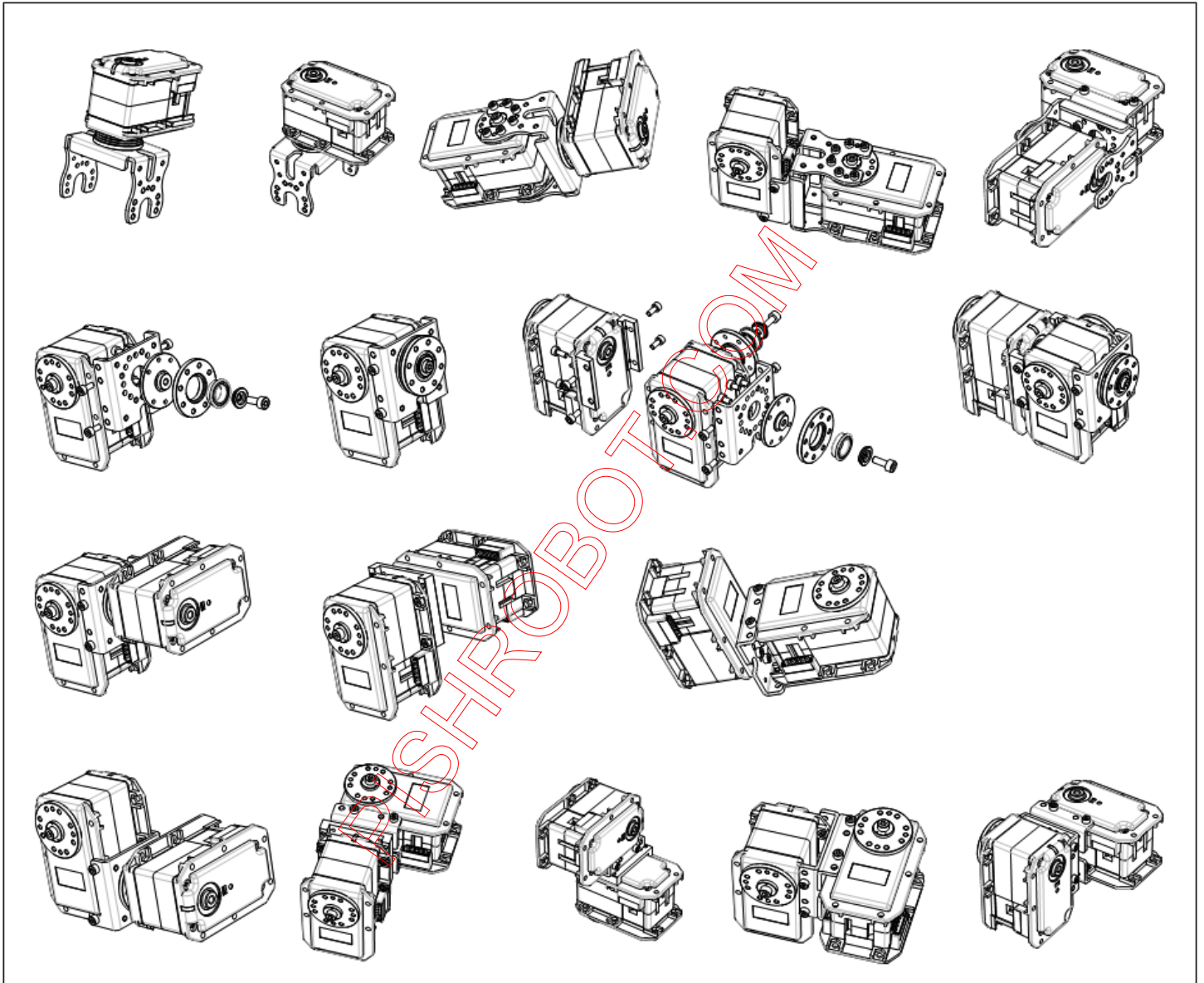

Option Frame (New Model)

The types of RX-28 option frame are as follows.

FR05-B101

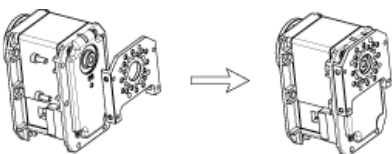

FR05-F101_FR05-X101

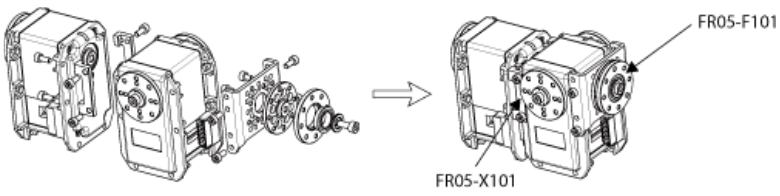

FR05-H101

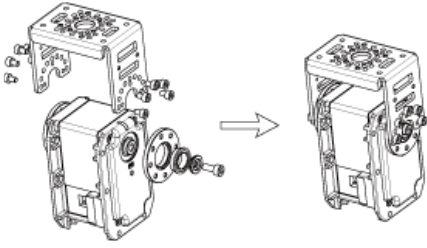

FR05-S101

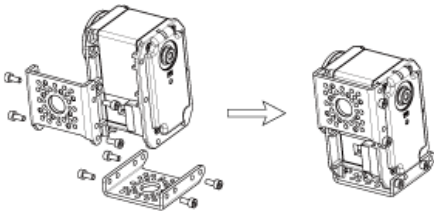

Horn (New Model)

The types of RX-64 Horn are as follows.

HN05-I101

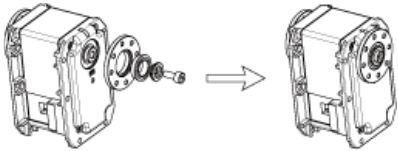

HN05-N101



HN05-T101

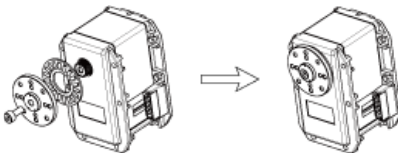

Combination (New Model)

The following example shows the combination structure of option frames and horns.

PISHROBOT.COM

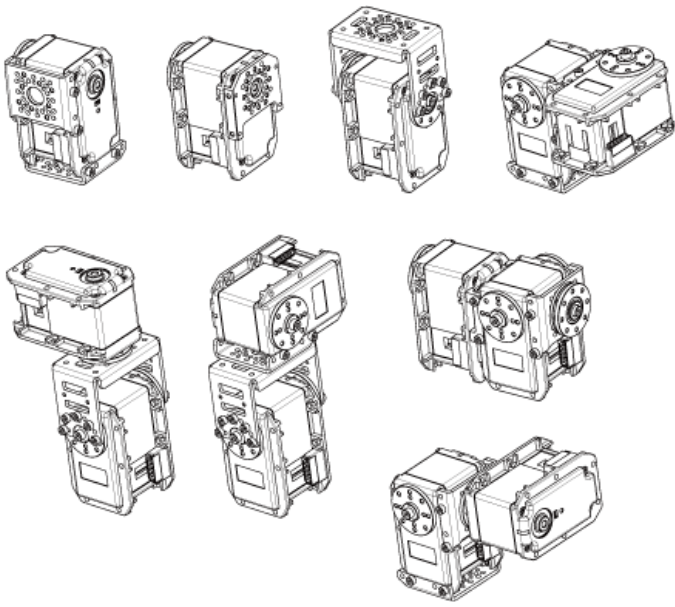

Dimension

Drawing Information : [DOWNLOAD](#) RX64Dimension.pdf

[Error Report](#)

Copyrights (c) 2010 [ROBOTIS](#) All rights reserved.

PISHROBOT.COM